

PRESSURE RELIEF VALVES TRANSCRITICAL CO₂



The 5701AX pressure relief valve is specifically designed for high pressure applications from 46 bar up to 130 bar and in particular, transcritical CO₂ systems. The valve is manufactured from Brass.

Main features

- Maximum pressure setting of 130 bar
- In accordance with EN ISO 4126, the valve reseats within 15% of set pressure following a discharge
- High flow capacity
- Fluoroelastomer soft seat material provides excellent sealing characteristics
- Allowable operating temperature = -40°C to +120°C
- Suitable for HFC, HCFC and CO₂ refrigerant gases

Standard pressure settings (barg): 46, 60, 80, 100, 120, 130

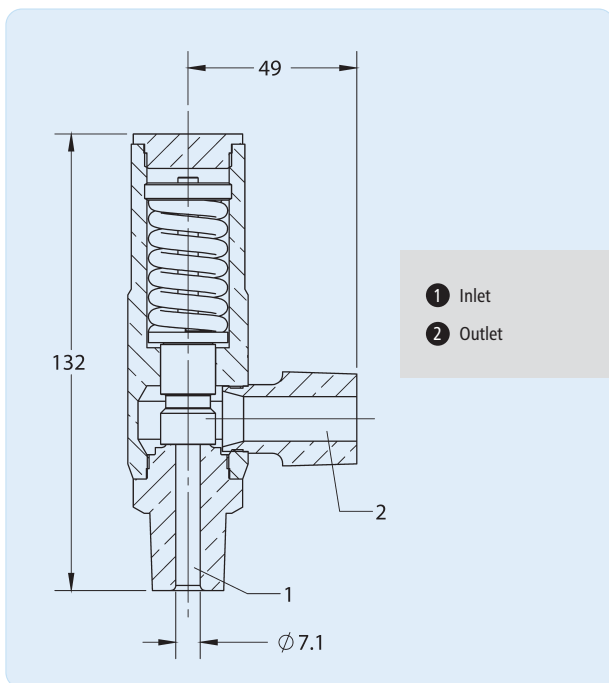

Valve Capacity Ratings (kg Air/min) @ 20°C						
Part No.	Standard Pressure Setting					
	46.0	60.0	80.0	100.0	120.0	130.0
5701AX	20.4	26.6	35.5	44.4	53.2	57.7

High Pressure Angle Relief Valve - Brass						
Part No.	Conn Size (inch)		Flow Area (mm ²)	K _{dr}	Weight (kg)	CE Cat
	Inlet	Outlet				
5701AX	1/2 NPTF	3/4 NPTF	39.59	0.71	0.82	Cat IV

Note: High pressure rupture disc (with pressure settings up to 130 barg) available on request.

Selection Guidelines

For safety reasons, relief valve selection should only be carried out by suitably qualified engineers.

Henry Technologies pressure relief valves are designed to discharge refrigerant vapour and are not recommended for liquid use.

The European Standards EN378 (reference 1) and EN13136 (reference 2) are recommended for PRV selection.

Example

A liquid receiver is to be protected from over-pressure due to fire.

Receiver dimensions = 2.016m long (L) x 0.841m outside diameter (D)

Refrigerant = R744 (CO₂)

Pressure Setting = 50.0 barg

$$Q_{md} = \frac{3600 \times \varphi \times A_{surf}}{h_{vap}}$$

Q_{md} = Minimum required discharge capacity, of refrigerant, of the pressure relief valve (kg/hour).

φ = Density of heat flow rate (kW/m²). The standards assume a value to 10 kW/m² but state that a higher value can be used if necessary. This figure relates to an un-lagged vessel.

A_{surf} = External surface area of the vessel (m²)

h_{vap} = Heat of vaporisation calculated at 1.1 times the set pressure, in bar a, of the pressure relief valve (kJ/kg)

Note:

When the relief valve setting is close to the critical pressure of the refrigerant, this sizing method may not be applicable.

$$A_{surf} = (\pi \times D \times L) + 2 \left(\frac{D^2 \times \pi}{4} \right)$$

$$A_{surf} = (\pi \times 0.841 \times 2.016) + 2 \left(\frac{0.841^2 \times \pi}{4} \right) = 6.44m^2$$

Calculate the heat of vaporisation, h_{vap} , taken at 1.1 times set pressure:

$$P_o = (P_{set} \times 1.1) + P_{atmos} = (50.0 \times 1.1) + 1.013 = 56.01 \text{ bar a}$$

From refrigerant property tables, use saturated vapour and liquid enthalpies at P_o .

Vapour = 410.59 kJ/kg

Liquid = 252.44 kJ/kg

$$h_{vap} = 410.59 - 252.44 = 158.15 \text{ kJ/kg}$$

The minimum required discharge rate of R744 can now be calculated for this vessel and set pressure:

$$Q_{md} = \frac{3600 \times \varphi \times A_{surf}}{h_{vap}} = \frac{3600 \times 10 \times 6.44}{158.15} = 1,465.95 \text{ kg/hr, R744}$$

For relief valve discharge capacity, Q_m :

$$Q_m = 0.2883 \times C \times A \times K_{dr} \times K_b \times \sqrt{\frac{P_o}{V_o}}$$

Q_m = Discharge capacity, of refrigerant, of the pressure relief valve (kg/hr)

C = Function of the isentropic exponent

A = Flow area of PRV (mm²)

K_{dr} = De-rated coefficient of discharge of PRV

K_b = Theoretical capacity correction factor for sub-critical flow.
A value of 1 is used for critical flow.

P_o = Actual relieving pressure of PRV (bar a)

V_o = Specific volume of saturated vapour at P_o (m³/kg)

Refrigerant data should be referenced for values of C and V_o .

The objective is to select a PRV which results in $Q_m > Q_{md}$. In this way, the relieving capacity of the PRV is greater than required thus avoiding excessive vessel pressure.

For this example, a 5701AX has been selected:

$A = 39.59 \text{ mm}^2$

$K_{dr} = 0.71$

$$Q_m = 0.2883 \times 2.63 \times 39.59 \times 0.71 \times 1 \times \sqrt{\frac{56.01}{0.0054}} = 2,170.6 \text{ kg/hr, R744}$$

$Q_m > Q_{md}$, therefore the 5701AX would be suitable for this system.

Important selection notes:

1. It is important not to grossly over-size a PRV so that Q_m is many times greater than Q_{md} as the performance of the PRV can be affected. Contact Henry Technologies for further guidance.
2. Henry Technologies recommends inlet and outlet piping for all PRVs are sized in accordance with EN13136 (reference 2) to avoid excessive pressure losses which can affect valve performance.
3. If a Henry Technologies rupture disc is used in conjunction with a Henry Technologies PRV, the PRV capacity should be de-rated by 10%. In the above example, the PRV capacity would be de-rated to 1,953.5 kg/hr (2,170.6 x 0.9).

References:-

1. BS EN 378-2:2008+A2:2012*
2. BS EN 13136:2001*

*Latest revisions at the time of publication. The user should ensure the latest revisions are referenced.

Installation – Main issues

1. Connect the relief valve at a location above the liquid refrigerant level, in the vapour space. Stop valves should not be located between the vessel and the relief valve except the three-way type.
2. Do not discharge the relief valve prior to installation or when pressure testing the system.
3. Pressure relief valves should be mounted vertically.
4. Relief valves should be changed out after discharge. Most systems are subject to accumulations of debris and particles of metal and dirt are generally blown onto relief valve seats during discharge. This can inhibit the relief valve from re-sealing at the original set pressure. A valve can also relieve at a lower pressure than the stamped setting due to the force of the re-closing action.
5. The pipe-work must not impose loads on the relief valve. Loads can occur due to misalignment, thermal expansion, discharge gas thrust, etc.
6. Transcritical CO₂ systems should generally be sized with the shortest length and largest bore outlet pipe work practical to avoid solids forming downstream of the PRV during a discharge.